

**ТЕРМОПОМПЕНИ СИСТЕМИ ZUBADAN ~ ВЪЗДУХ - ВОДА**  
*ZUBADAN HEAT PUMPS ~ AIR-TO-WATER SYSTEMS*

**ZUBADAN**

**ЦЕНОВА ЛИСТА 2009/2010**  
*LIST PRICE 2009/2010*



- ① Термо Помпа
- ② Пластинчат топлообменник(осигурява се от клиента)
- ③ Бойлер (осигурява се от клиента)
- ④ Радиатор
- ⑤ Душ Кабина
- ⑥ Мивка

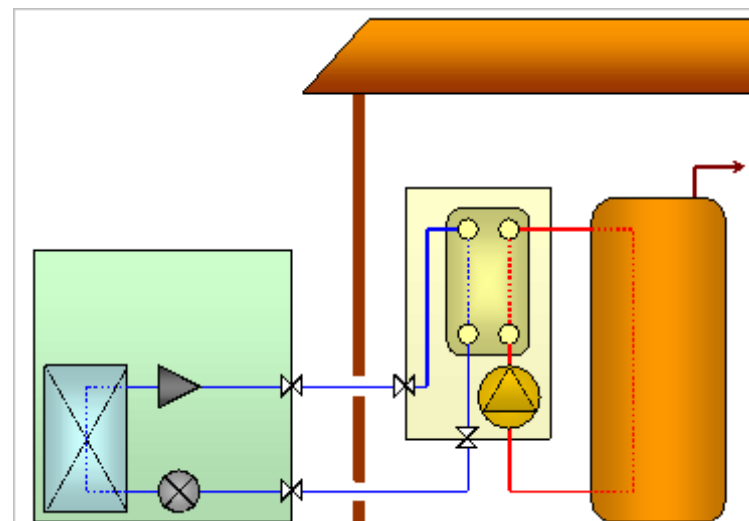

<b>I Separate Type - Power Inverter</b>												
No. ред	Модел / Model	Тип / Type	Q <sub>ох</sub> [kW]	EER	RANK	Q <sub>от</sub> [kW]	COP	RANK	dB(A)	Price incl VAT in Euro	Цена с ДДС в Лева	
1	PUHZ-RP50 VHA	Инверт. агрегат Power Inverter	2,3-5,7	3.21	A	2,5-6,6	3.62	A	41	€ 1 868.64	3 654.74 лв	
2	PUHZ-RP60 VHA	Инверт. агрегат Power Inverter	2,7-6,7	3.23	A	2,8-8,2	3.61	A	44	€ 2 084.88	4 077.67 лв	
3	PUHZ-RP71 VHA	Инверт. агрегат Power Inverter	3,3-8,1	3.62	A	3,5-10,2	3.62	A	44	€ 2 260.32	4 420.80 лв	
4	PUHZ-RP100 VHA	Инверт. агрегат Power Inverter	4,9-11,4	3.8	A	4,5-14,0	3.71	A	46	€ 2 794.80	5 466.15 лв	
5	PUHZ-RP125 VHA	Инверт. агрегат Power Inverter	5,5-14,0	3.22	A	5,0-16,0	3.61	A	47	€ 2 856.00	5 585.85 лв	
6	PUHZ-RP140 VHA	Инверт. агрегат Power Inverter	6,2-15,3	3.21	A	5,7-18,0	3.61	A	47	€ 3 523.08	6 890.55 лв	
7	PAC-IF021B-E	LEV-KIT AIR TO WATER с RAR-W21MAA									€ 927.96	1 814.93 лв
8	PAC-IF031B-E	LEV-KIT AIR TO WATER с RAR-W21MAA									€ 1 027.86	2 010.32 лв
9	PAC-IF020B-E	LEV-KIT AIR TO WATER									€ 470.64	920.49 лв
10	ACH-70X-20M	Brazen Plate Heat Exchanger - R410A									€ 623.49	1 219.45 лв
11	EH-S20	ECODAN SPLIT SYSTEMS	STE EHST 20BYS9 (with plate heat exchanger)							€ 6 109.80	11 949.73 лв	

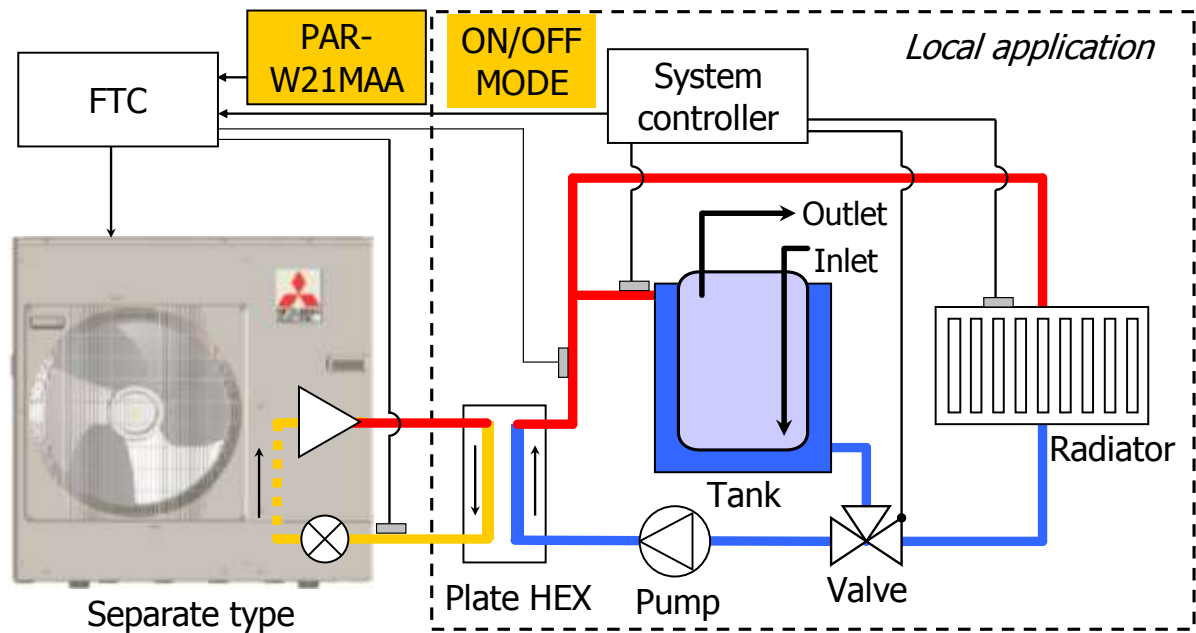

<b>Separate Type - Zuba-Dan</b>												
No. ред	Модел / Model	Тип / Type	Q <sub>ох</sub> [kW]	EER	RANK	Q <sub>от</sub> [kW]	COP	RANK	dB(A)	Price incl VAT in Euro	Цена с ДДС в Лева	
1	PUHZ-HRP71 VHA2	Инверт. агрегат Zuba-Dan	4,9-8,1	3.66	A	4,5-10,2	4.21	A	48	€ 3 992.28	7 808.22 лв	
2	PUHZ-HRP100 VHA2	Инверт. агрегат Zuba-Dan	4,9-11,4	4.1	A	4,5-14,0	4.41	A	48	€ 4 455.36	8 713.93 лв	
3	PUHZ-HRP100 YHA2	Инверт. агрегат Zuba-Dan	4,9-11,4	4	A	4,5-14,0	4.31	A	48	€ 4 832.76	9 452.06 лв	
4	PUHZ-HRP125 YHA2	Инверт. агрегат Zuba-Dan	5,5-14,0	3.3	A	5,0-16,0	3.92	A	48	€ 5 210.16	10 190.19 лв	
5	PAC-IF021B-E	LEV-KIT AIR TO WATER c RAR-W21MAA									€ 927.96	1 814.93 лв
6	PAC-IF031B-E	LEV-KIT AIR TO WATER c RAR-W21MAA									€ 1 027.86	2 010.32 лв
7	PAC-IF020B-E	LEV-KIT AIR TO WATER									€ 470.64	920.49 лв
8	ACH-70X-20M	Brazen Plate Heat Exchanger - R410A									€ 623.49	1 219.45 лв
9	EH-S20	ECODAN SPLIT SYSTEMS	STE EHST 20BYS9 (with plate heat exchanger)							€ 6 109.80	11 949.73 лв	

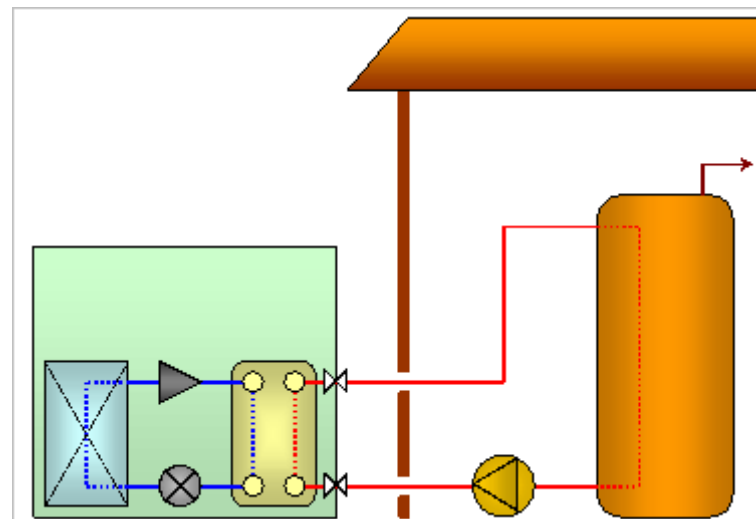

<b>III Compact Type - Power Inverter</b>												
№.ред	Модел / Model	Тип / Type	Q <sub>ох</sub> [kW]	EER	RANK	Q <sub>от</sub> [kW]	COP	RANK	dB(A)	Price incl VAT in Euro	Цена с ДДС в Лева	
1	PUHZ-W50 VHA	Air to water Compact Units Power Inverter	4,5	4.13	A	5,0	4.1	A	45	€ 3 739.32	7 313.47 лв	
2	PUHZ-W85 VHA	Air to water Compact Units Power Inverter	7,5	3.87	A	9,0	3.85	A	48	€ 5 546.76	10 848.52 лв	
3	PAC-IF021B	LEV-KIT AIR TO WATER с RAR-W21MAA								€ 927.96	1 814.93 лв	
4	PAC-IF031B	LEV-KIT AIR TO WATER с RAR-W21MAA								€ 1 027.86	2 010.32 лв	
5	PAC-IF020B	LEV-KIT AIR TO WATER								€ 470.64	920.49 лв	
6	EH-P20	ECODAN SPLIT SYSTEMS	<a href="#">STE EHST 20XYS9 (without plate heat exchanger)</a>								€ 5 620.20	10 992.16 лв

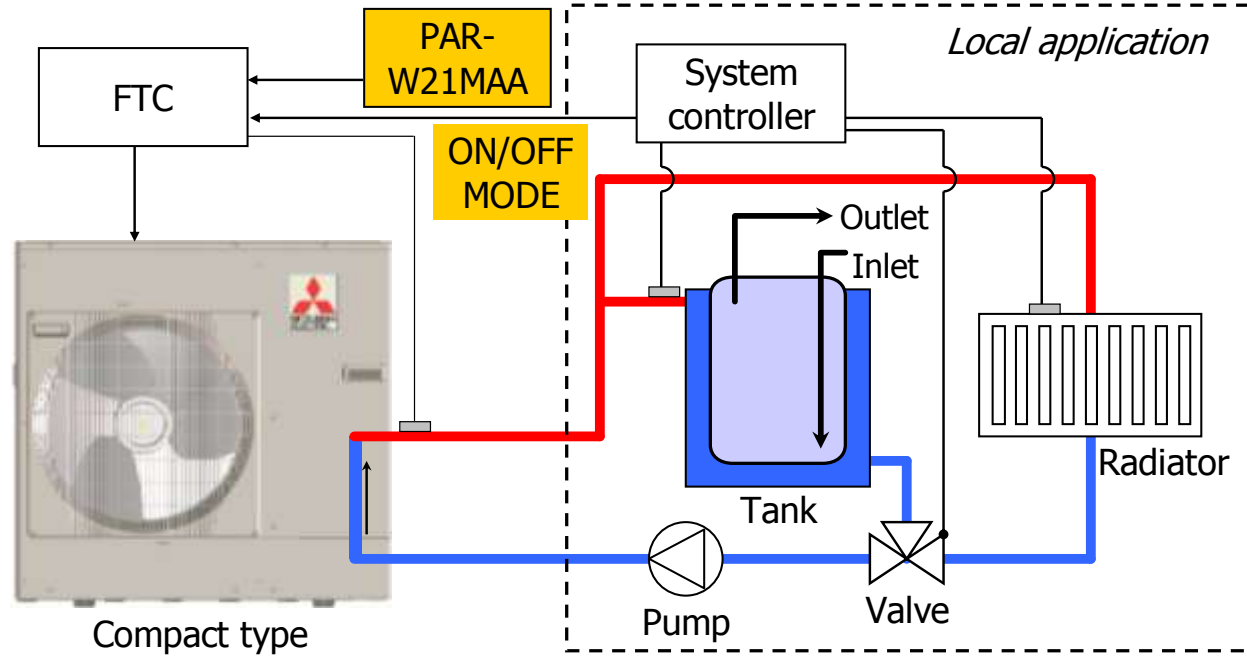

<b>IV Compact Type - Zuba-Dan</b>												
No. ред	Модел / Model	Тип / Type	Q <sub>ох</sub> [kW]	EER	RANK	Q <sub>от</sub> [kW]	COP	RANK	dB(A)	Price incl VAT in Euro	Цена с ДДС в Лева	
1	PUHZ-HW112 YHA	Air to water "Compact Units"	10,0	4.07	A	11,2	4.24	A	53	€ 7 754.04	15 165.58 лв	
2	PUHZ-HW140 VHA	Air to water "Compact Units"	12,5	4.01	A	14,0	4.19	A	53	€ 8 174.28	15 987.50 лв	
3	PUHZ-HW140 YHA	Air to water "Compact Units"	12,5	4.01	A	14,0	4.19	A	53	€ 8 594.52	16 809.42 лв	
4	PAC-IF021B	LEV-KIT AIR TO WATER с RAR-W21MAA									€ 927.96	1 814.93 лв
5	PAC-IF031B	LEV-KIT AIR TO WATER с RAR-W21MAA									€ 1 027.86	2 010.32 лв
6	PAC-IF020B	LEV-KIT AIR TO WATER									€ 470.64	920.49 лв
7	EH-P20	ECODAN COMPACT SYSTEMS	STE EHST 20XYS9 (without plate heat exchanger)								€ 5 620.20	10 992.16 лв

## Примерна Схема за работа на системата с PAC-IF031B

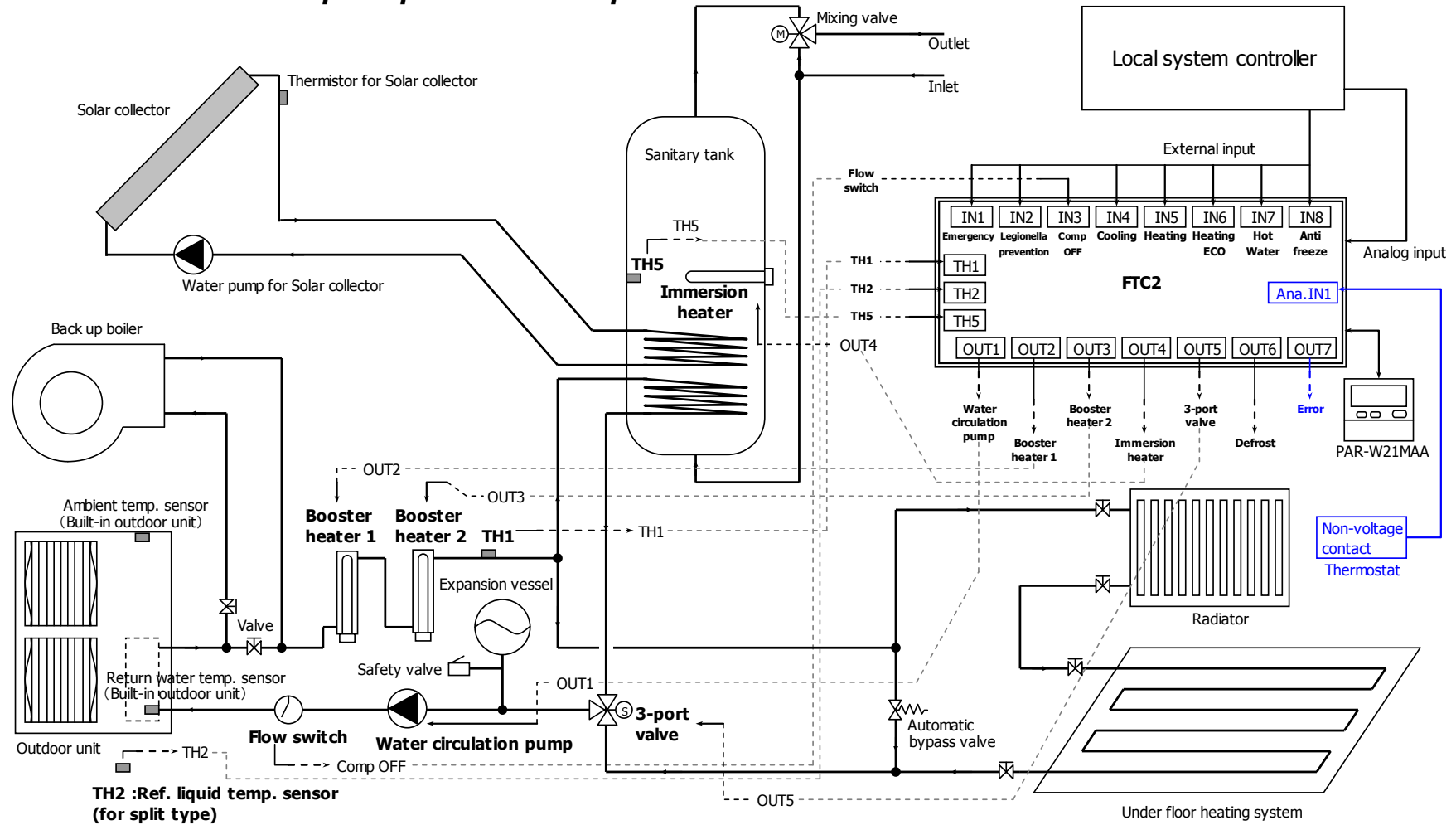

# ZUBADAN

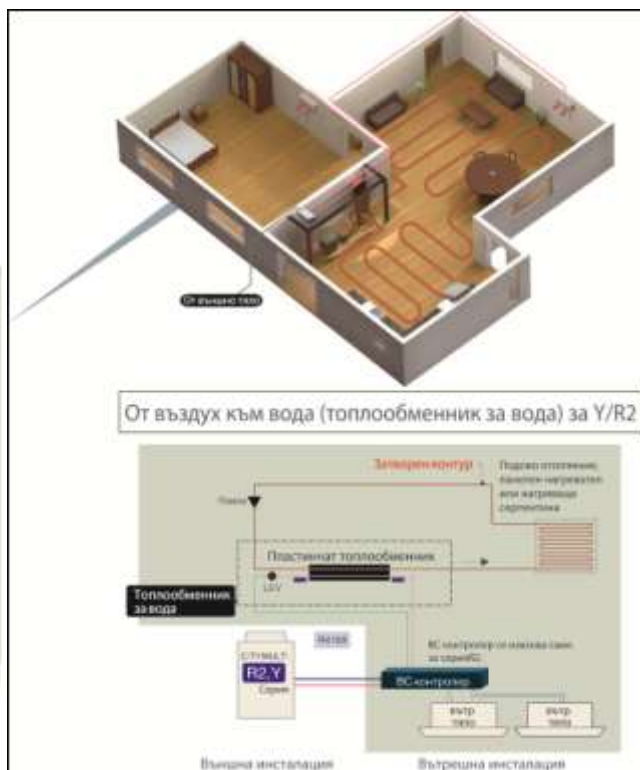

Постоянна топлинна ефективност дори при  $-15^{\circ}\text{C}$

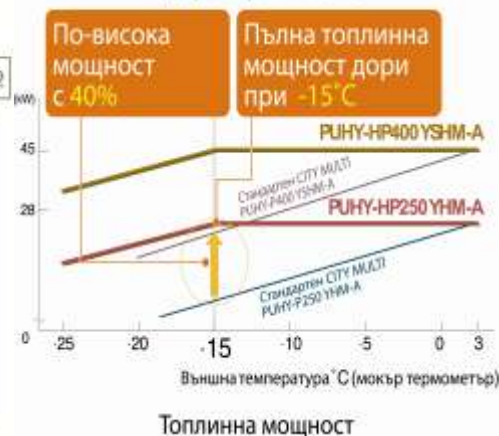

## City Milti - Zuba-Dan

No. ред	Модел / Model	Тип / Type	Q <sub>ох</sub> [kW]	EER	RANK	Q <sub>от</sub> [kW]	COP	RAN K	dB(A)	Price incl VAT in Euro	Цена с ДДС в Лева
1	PWFY-P100VM-E-AU	HWS	11.2	10-35 $^{\circ}\text{C}$		12.5	10-40 $^{\circ}\text{C}$		29	€ 2 331.72	4 560.45 лв
2	PWFY-P200VM-E-AU	HWS	22.4	10-35 $^{\circ}\text{C}$		25	10-40 $^{\circ}\text{C}$		29	€ 3 908.64	7 644.64 лв
3	PUHY-HP200 YHM-A	VRFТерм.Помп.Агрегат Zubadan	22.4	3.5	A	25	3.83	A	56	€ 10 758.96	21 042.70 лв
4	PUHY-HP250 YHM-A	VRFТерм.Помп.Агрегат Zubadan	28	3.09	B	31.5	3.52	A	57	€ 13 090.68	25 603.14 лв
5	RAR-W21MAA	Дистанционно управление								€ 273.06	534.06 лв
6	CMY-R100VBK	Тройник разпределител								€ 295.26	577.48 лв